

Tandem Collimators System

(Tandem Collimators for the Tangential GammaRay Spectrometer – KM6T–TC)

S. Soare¹, T. Craciunescu², M. Curuia¹, V. Zoita^{1,2}

¹ National Research and Development Institute for Cryogenics and Isotopic Technologies

² National Institute for Laser, Plasma and Radiation Physics

1. General objectives

Gamma-ray diagnostics at JET (gamma-ray spectrometry [1] and imaging [2]) have provided some of the most interesting results in experiments such as those of the TTE campaign [3]. The extension of the application of this diagnostics to high power deuterium and, especially, deuterium–tritium discharges is however limited by the present capabilities of these diagnostics. For instance, with the existing diagnostics capabilities the gamma-ray signal is completely overwhelmed by neutron events even in JET discharges using a few MW's of neutral beams. A coherent set of upgrades was therefore considered indispensable to extend the JET gamma-ray diagnostic capabilities and to improve the measurements in order to better support the experimental programme.

In this respect, within the GRC EP2 Enhancement project the matter of the operation of the gamma-ray detectors in intense neutron and gamma-ray fields was addressed for two of the JET gamma-ray diagnostics:

- The KN3 Gamma-Ray Cameras
- The KM6T Tangential Gamma-Ray Spectrometer

Design solutions based on water neutron attenuators have been developed for the KN3 Gamma-Ray Cameras (the KN3-NA diagnostics upgrade) [4].

A conceptual design was produced for the full line-of-sight of the KM6T Tangential Gamma-Ray Spectrometer [5], with the main design target being the maximisation of the “signal to background ratio” at the spectrometer detector, the ratio being defined in terms of the plasma emitted gamma radiation and the gamma-ray background.

The Conceptual Design Report [6] presents a complex system of collimators and shields for both the neutron and gamma radiations which define the spectrometer field of view, figure 1a and 1b. Two tandem collimators determine the field of view through the tokamak plasma. The entrance aperture to the penetration in the JET Torus Hall south wall is defined by a neutron shield. Two gamma-ray shields together with the existing concrete collimator determine the field of view at the gamma-ray detector. One of the gamma-ray shields (with an embedded neutron attenuator) can be remotely moved in and out of the detector line of sight thus providing flexibility in definition of the neutron and gamma-ray fields at the gamma-ray spectrometer detector (a BGO scintillator detector).

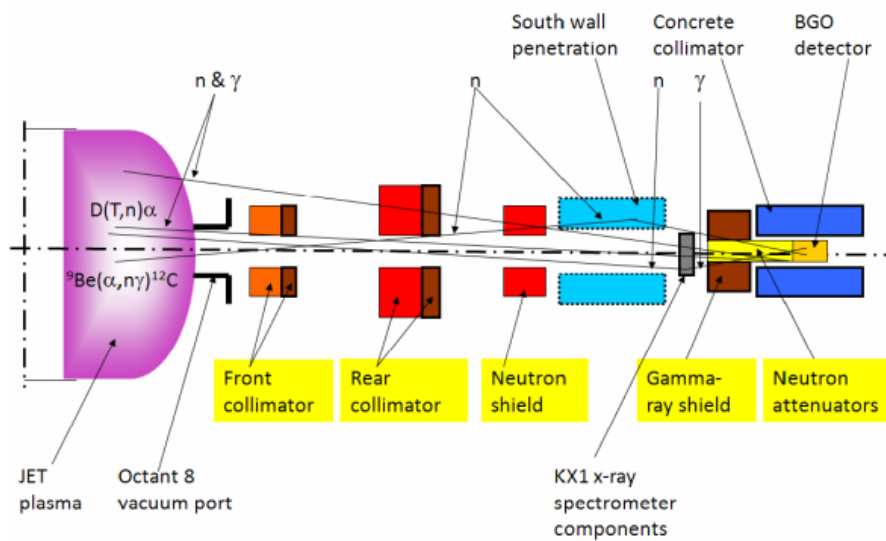

Figure 1.1.a. Tangential gamma-ray spectrometer: schematic representation of the full system

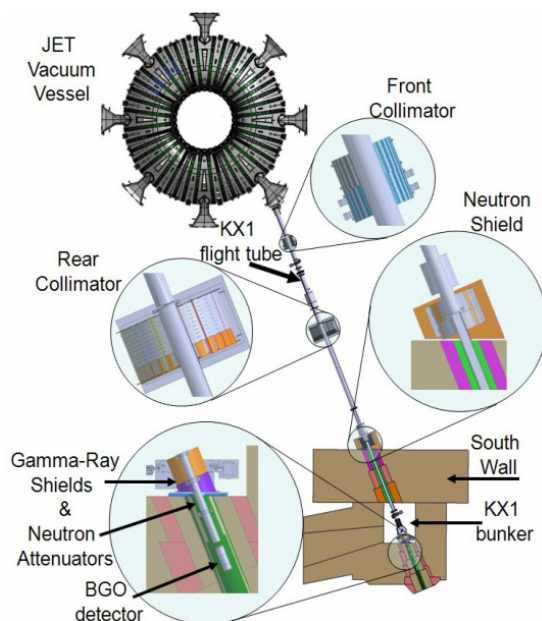

Figure 1.1.b. CAD (CATIA) model for the tangential gamma-ray spectrometer system.

Mid-plane cross-section

1.1 Specific Objectives

The present Enhancement project (TCS, Tandem Collimator System for the GammaRay Spectrometer - KM6T - TC) addresses the first two components of the upgraded diagnostics line-of-sight, figure 1.2.

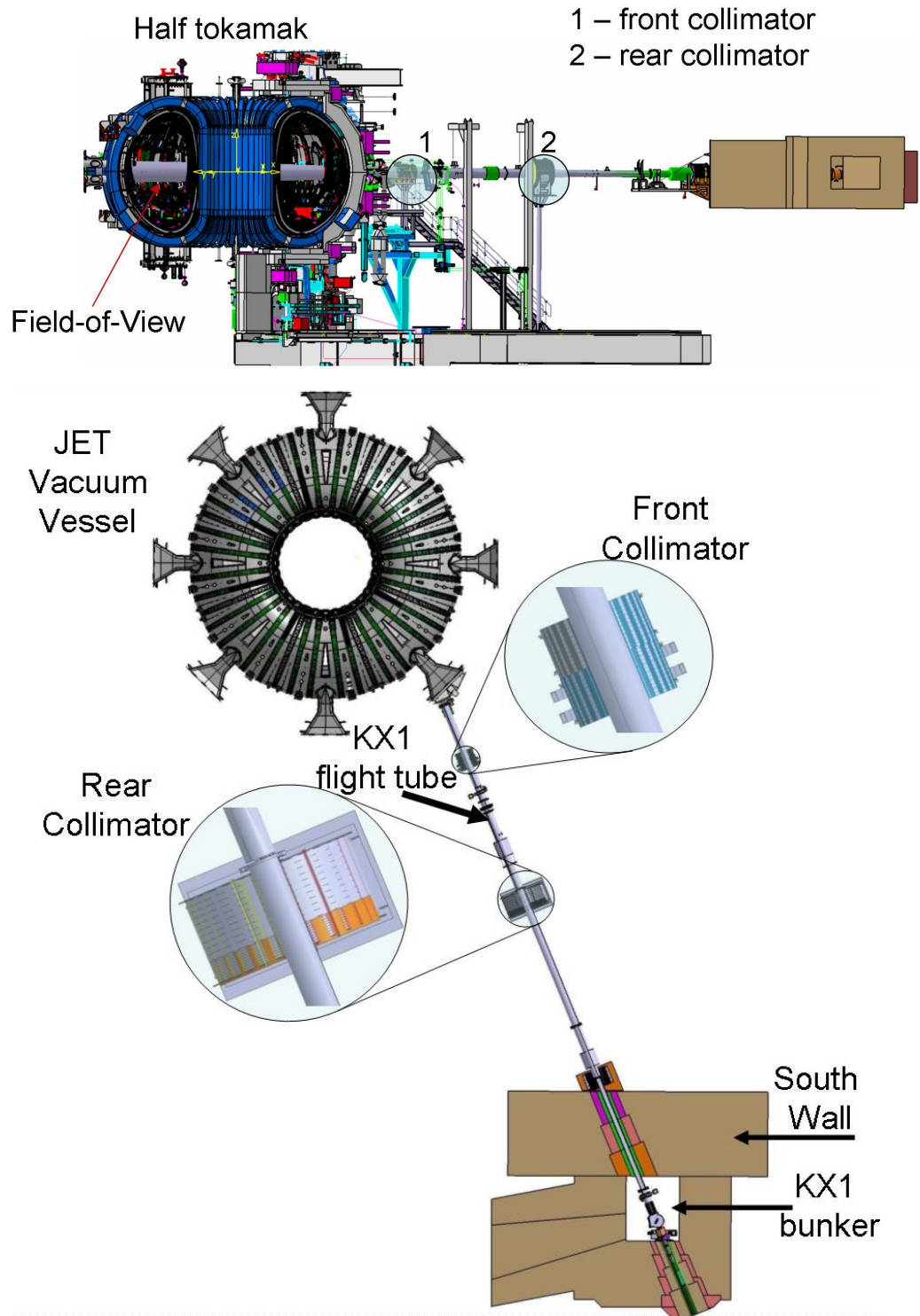

Figure 1.2 Locations of KM6T Tandem Collimators - side view and mid-plane section

The main aim of the TCS project is to provide a proper collimation for the gamma-ray (BGO) detector of the tangential gamma-ray spectrometer, with a well-

defined field of view at the plasma end of the diagnostics line-of-sight. The collimation system should at the same time improve the signal-to-background ratio at the detector end of the line-of-sight.

The radiation shield of the KJ5 (X-ray camera) diagnostics has served as a pre-collimator before the JET 2004 shutdown. The analysis done within the KM6T upgrade conceptual design [6] has shown that the KJ5 radiation shield has operated as a pre-collimator only along the vertical (radial) direction. Along the horizontal (toroidal) direction it allowed wide regions of the plasma (and parasitic sources) to be seen by the gamma-ray detector.

During the JET EP1 installation programme the KJ5 detector shield block was removed from the vicinity of the machine exit in Octant 8. The quality of the physics information from the KM6T spectrometer has been dramatically reduced by an increase in background events (huge cut in signal to background ratio plus loss of a well-defined field-of-view) to the extent that the data is now of little value.

A new collimation system is considered to be absolutely necessary in order to:

- regain the capability of this diagnostics essential for fast particle physics studies of JET plasmas
- provide necessary (but not sufficient) conditions for the operation of the diagnostics in high performance deuterium and deuterium-tritium JET discharges.

2. Components of the TCS Project

A system of two collimators, designed to work in tandem, was developed and favourably reviewed at the Scheme Design Review Meeting held in October 2009. The components of this system are:

2.1 Front Collimator

2.2. Rear Collimator

Both collimators are cylindrical in shape, with different dimensions (the rear collimator being larger). The modular structure of the collimators makes possible the use of the KM6T diagnostics in DD discharges (as such) and DT discharges (DD configuration with one additional module for each collimator).

The materials used to construct the collimators are:

- as collimating materials: slabs of Pb nuclear grade and high density polyethylene (HDPE) arranged in alternating pattern
- for casings: stainless steel (304)
- column support and saddle: steel (EN8)

The collimators axis are coincident with the KX1 beam line, the front collimator being placed at 1.3 m from the Octant 7 vacuum port door and the rear collimator 4.5m behind the front collimator, fig. 2.1.

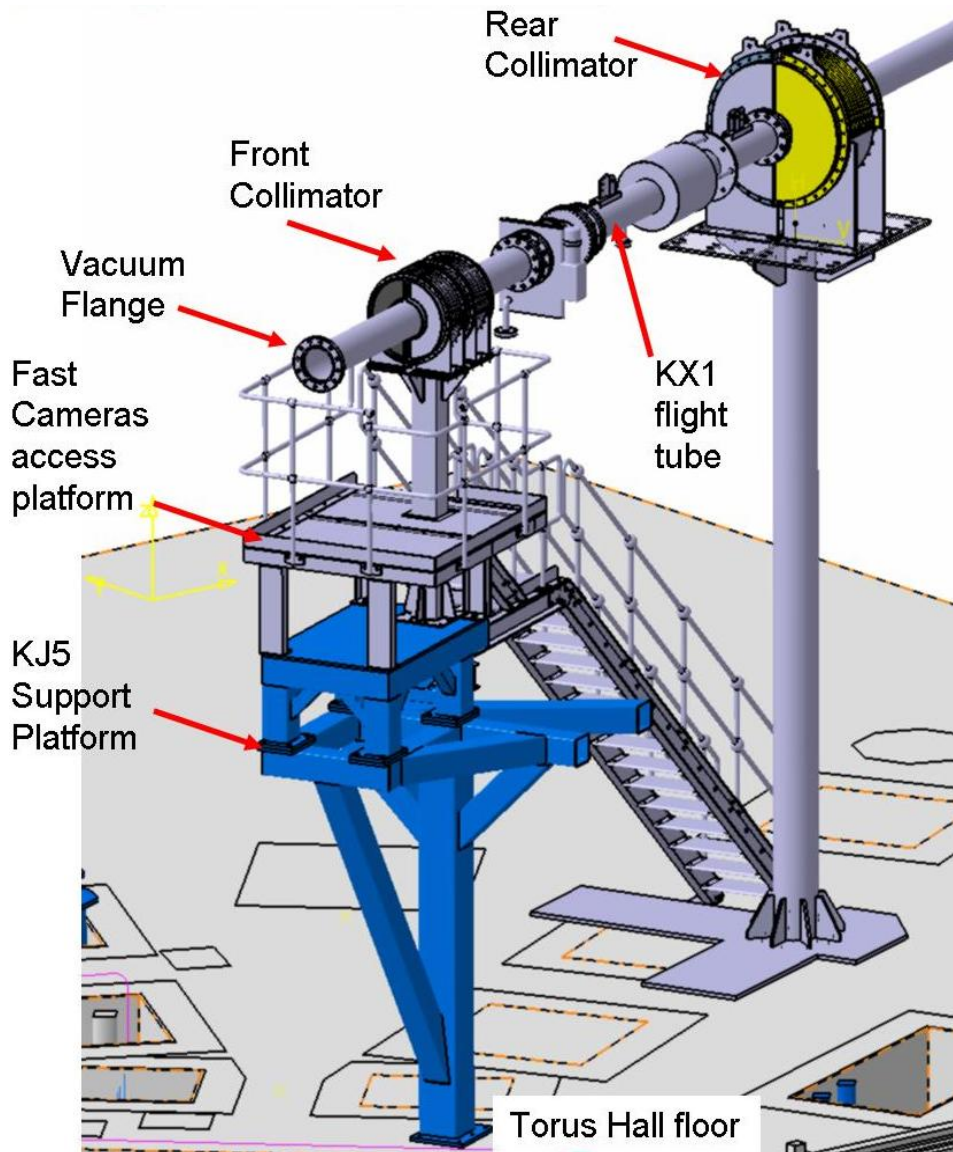

Figure 2.1 Tandem Collimators location

2.1 Front Collimator – individual collimator role

The front collimator defines the spectrometer field of view at the plasma side of the line-of-sight. Its dimensions (outer diameter and length) have been determined in terms of the available space in front of the JET Octant 8 vacuum port. The front collimator acts as a shield for both the neutron and gamma radiation. It uses polyethylene plates for the neutron collimation and led plates for the gamma-ray collimation.

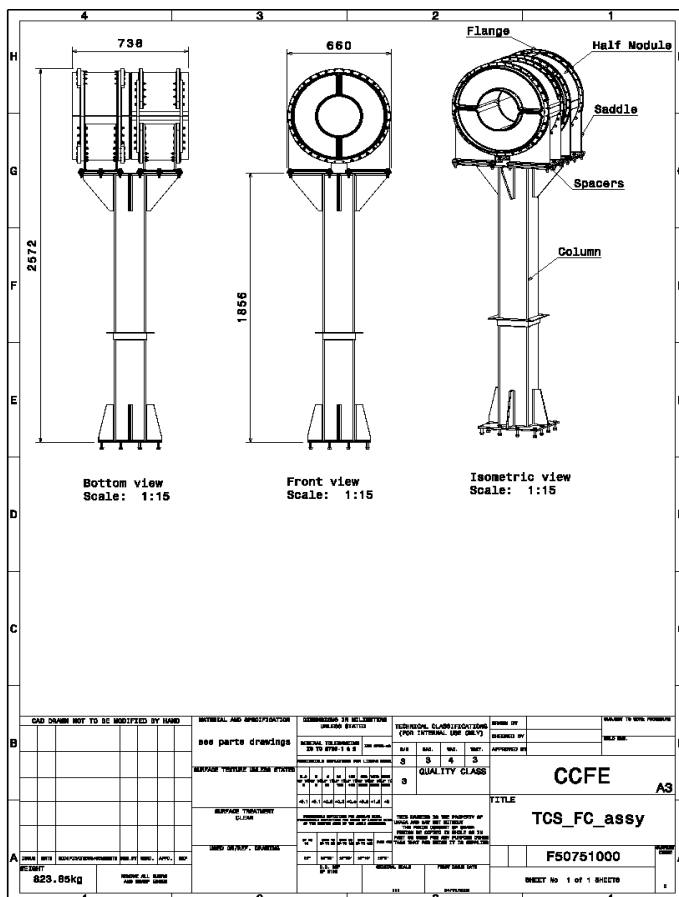
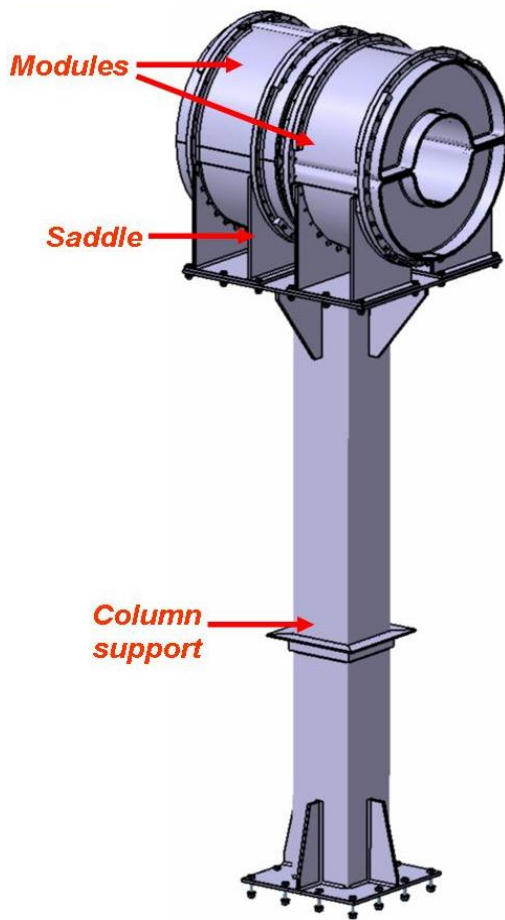

Figure 2.2 Front Collimator locations

The axis of the front collimator coincides with that of KX1 beam line, at 1.6 m above the fast cameras platform and at roughly 1.3 m from the KX1 vacuum port flange. It is a fixed structure, once positioned, the front collimator operation will not require any further movements.

The components of the front collimator assembly are the following, figure 2.2:

- support column
- saddle
- casings
- flanges
- active materials (high density polyethylene - HDPE and Pb - nuclear grade)
- a range of bolts, washers and nuts for fastening

2.2 Rear collimator – individual collimator role

The rear collimator defines (by its external diameter) the radial extension of the shielded field seen by the BGO gamma-ray detector. The thickness of the rear collimator is determined by the necessary amount of material needed to shield the BGO detector from parasitic neutron ($E_{\max} \sim 14.1$ MeV) and gamma radiation ($E_{\max} \sim 5$ MeV). The rear collimator is made up of polyethylene plates for the neutron collimation and lead plates for the gamma-ray collimation. The two collimators are designed to work in a tandem configuration.

The rear collimator structure is positioned at 4.6 m behind the front collimator toward the Torus Hall South Wall, fig. 2.3. The neutron and gamma-ray shields are enclosed in two casings at a height of 6.5 m above the floor level. The axis coincides with that of the KX1 beam line. The lower end of the support column is just under the ladder foot (figure 2.1), bridging a floor penetration.

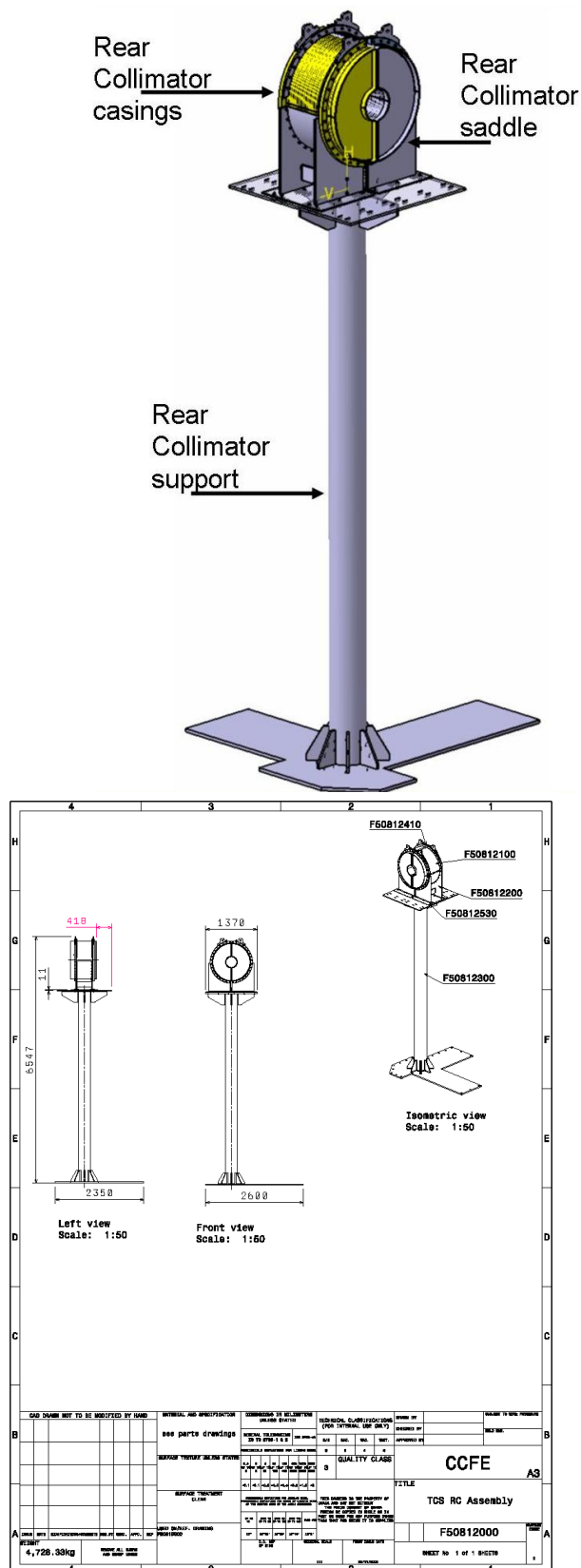

Figure 2.3 Rear Collimator

The components of rear collimator are shown in figure 2.3.

- casing
- saddle

- support column

3. Tandem Collimator System - design procedure

The development of the conceptual design solutions for the TGRS upgrade has been done through the following iterating procedure:

- Estimation of necessary materials and thicknesses to provide the required attenuation factors for neutrons and gamma-rays
- Evaluation of available space and determination of the positions of the collimators and shields
- Estimation of outer diameter and thickness for the collimators and shields
- CAD (CATIA) model for the new TCS configuration
- Simplified TCS model for the neutron-photon transport (MCNP) calculations
- Update of the CATIA model based on the results of the MCNP calculations

4. Evaluation of radiation (neutron and photon) performance of the KM6T Tandem Collimators

The evaluation of the physical performance of the tandem collimator system for the KM6T tangential gamma-ray spectrometer has addressed the elaboration of an optimized configuration (CONFIG-4) for 2.45 MeV and also the development of a collimation configuration (CONFIG-5) adapted for discharges using the DT mixture (14 MeV neutrons).

The radiation performance of the KM6T tandem collimators was evaluated by means of Monte Carlo numerical simulations using the MCNP-5 code. A full description of the radiation field at the position of the tandem collimators would involve complex and long duration calculations which are much beyond the possibilities (resources) of the TCS project. It was therefore decided to use the Monte Carlo simulation for the evaluation of the shielding characteristics of the KM6T tandem collimator assembly in a simplified geometry that uses point (neutron and photon) sources irradiating the collimators within a defined solid angle and detectors placed behind the collimators. In this geometry the numerical simulations provided, at the detector positions, the integrated neutron and photon fluxes and also neutron and photon spectra. The shielding characteristics of the tandem collimators was defined in terms of a shielding factor, which is the ratio of the radiation fluxes in two detectors: one placed on the axis of the system and another placed behind the collimators, at a mid-radius position (figure. 4.1).

For all the configurations used for the neutron and photon transport calculations the radiation sources were approximated by point sources.

- A point neutron source placed at the intersection of the KM6T axis with the (vertical projection of) magnetic axis. This is at a distance of approximately 4.8 m from the front face of the front collimator. The point neutron source has a Gaussian shape neutron spectrum with the mean energy at $E_0 = 2.45$ MeV and a full width at half maximum (FWHM) of 0.5 MeV.

- A point photon (gamma-ray) source placed at the intersection of the KM6T axis with a plane perpendicular to the surface of the inner wall guard limiter in Octant 2. This is at a distance of approximately 7.3 m from the front face of the front collimator. The photon source is represented by a single line of energy 9 MeV, corresponding to the most intense nickel neutron capture gamma-ray line expected to be emitted by the INCONEL support of the IWGL (figure 4.2).

In order to reduce the computation time (a typical run takes about 48 hours) the propagation space was limited to a reduced solid angle. A 20° angle was chosen, and this is 5 times the angle subtended by the front face of the front collimator. A number of 2×10^9 particles were propagated. In order to improve the statistics the volume of the detectors have been considerably increased. While the envisaged detectors (neutron bubble detectors) to be used for the KM6T tandem collimator measurements have a diameter of about 20 mm, the detectors in the CONFIG3 configuration have a diameter of 100 mm.

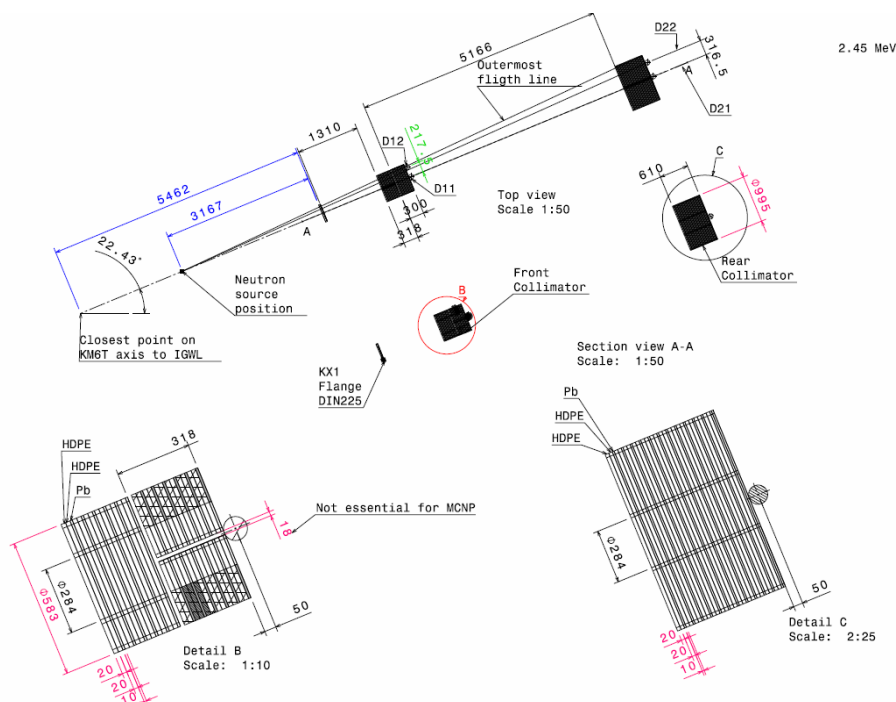

Figure 4.1- KM6T-TC configuration CONFIG-4 used for the Monte Carlo simulations

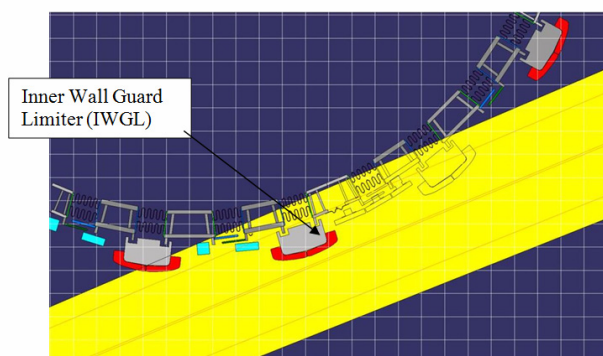

Figure 4.2 - Parasitic gamma-ray sources: IWGL's and their supports

The main characteristics of the two configurations are the following:

	CONFIG-4 (Fig. 4.1)	CONFIG-5 (Fig. 4.3)
front collimator	made up of 12 alternating polyethylene (thickness 40 mm) and lead (thickness 10 mm) plates. A polyethylene plate is placed at the front face of the front collimator.	made up of 18 alternating polyethylene (thickness 40 mm) and lead (thickness 10 mm) plates. A polyethylene plate is placed at the front face of the front collimator.
rear collimator	the rear collimator made up of 12 alternating polyethylene (thickness 40 mm) and lead (thickness 10 mm) plates. The rear collimator has an additional 10 mm lead plate at the rear face. A polyethylene plate is placed at the front face of the rear collimator.	made up of 24 alternating polyethylene (thickness 40 mm) and lead (thickness 10 mm) plates. The rear collimator has an additional 10 mm lead plate at the rear face. A polyethylene plate is placed at the front face of the rear collimator.

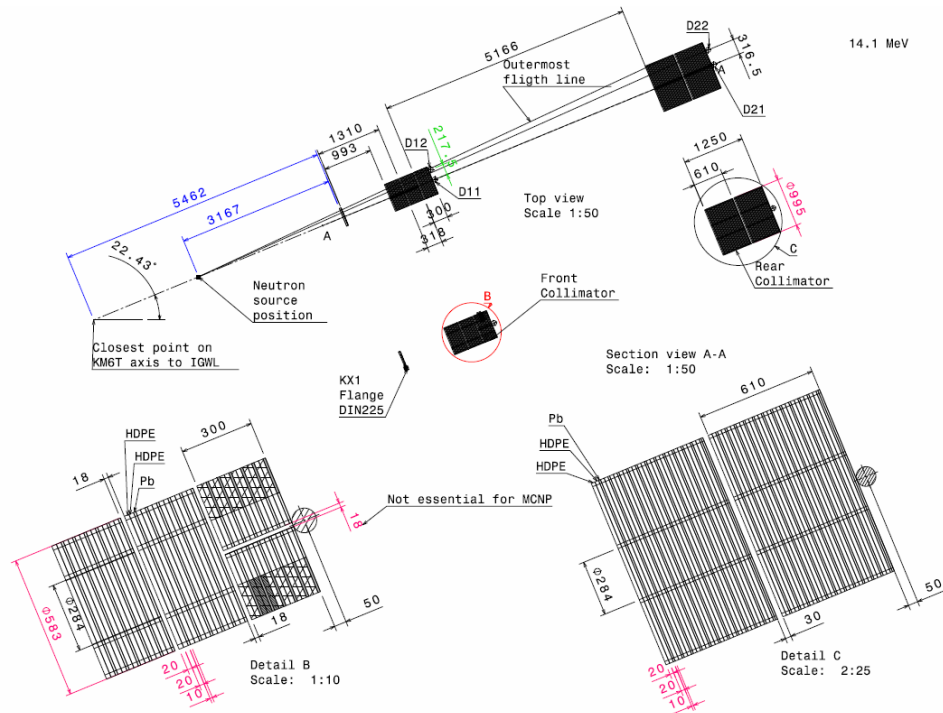

Figure 4.3- KM6T-TC configuration CONFIG-5 used for the Monte Carlo simulations

Table 4.1 - shielding factor for the CONFIG4 configuration

D1/D2	Front collimator	Rear collimator	Rear collimator after replacing last two polyethylene layers by borated polyethylene.
N	19 ± 1	246 ± 5	305 ± 22
(n, γ)	5 ± 1	96 ± 14	243 ± 68
γ (9 MeV)	45 ± 0.7	464 ± 50	

Table 1. presents the shielding factor D1/D2 for MCNP runs on the CONFIG4 configuration.

The analysis demonstrates that the KM6T tandem collimators produce very good values for the shielding factor, both for neutrons and for the parasitic gamma-ray sources. The influence of changing the material of last two layers of the rear collimator was also assessed. Polyethylene was replaced by borated polyethylene in order to reduce the flux of photons generated by neutron capture. Neutrons and photons spectra are presented in Fig. 4 and the shielding factors are listed also in Table 4.1.

For the propagation of the nickel 9 MeV gamma-ray line the results for concerning the shielding factor are presented also in Table 4.1.

The CONFIG-4 configuration developed for deuterium discharges, provides shielding factors of about 250 for 2.45 MeV neutrons, 100 for neutron-capture photons

induced within the collimation structure and about 450 for a parasitic gamma-ray line of 9 MeV. When two polyethylene collimation plates are replaced by two boronated polyethylene plates a substantial increase (x2.5) is obtained in the n-capture photon shielding factor. It is thus highly recommended to include such boronated plates in the structure of the rear collimator in spite of the increase in cost.

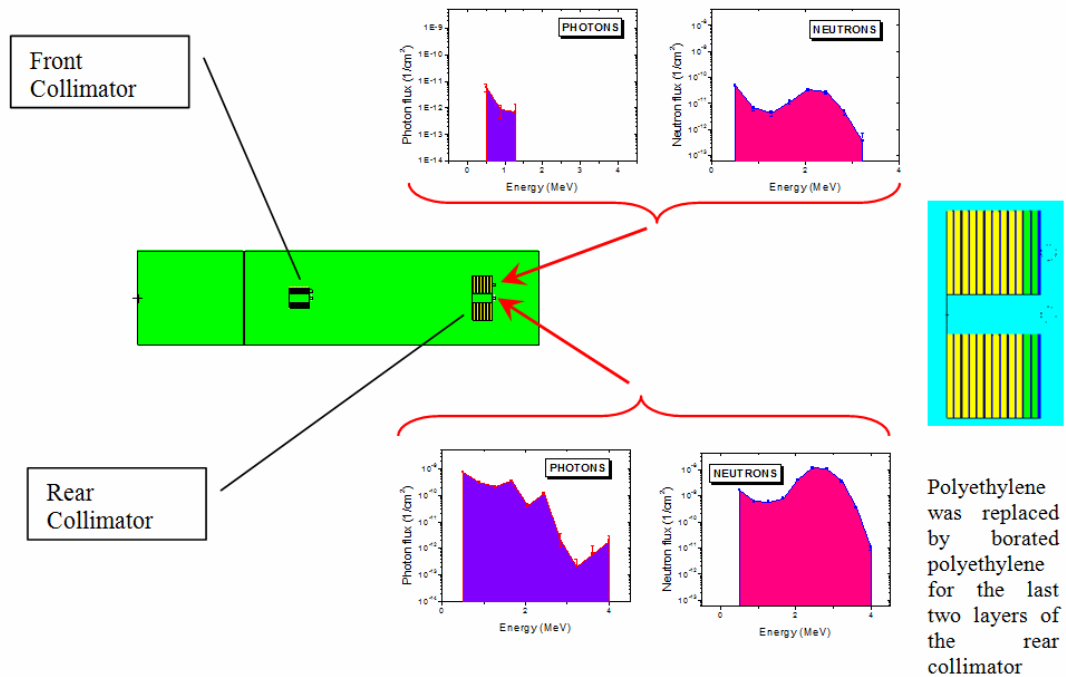

Figure 4.4 - Simulation results for CONFIG4 configuration (neutron and photon induced energy distributions) when replacing polyethylene with borated polyethylene in the last two layers of the rear collimator

CONFIG-5 configuration was designed in order to obtain similar shielding parameters as in the case of 2.5 MeV neutron emission, for D-T experiments, when 14 MeV neutron emission occur. The shielding factor values are presented in figure 4.5 and Table 2.

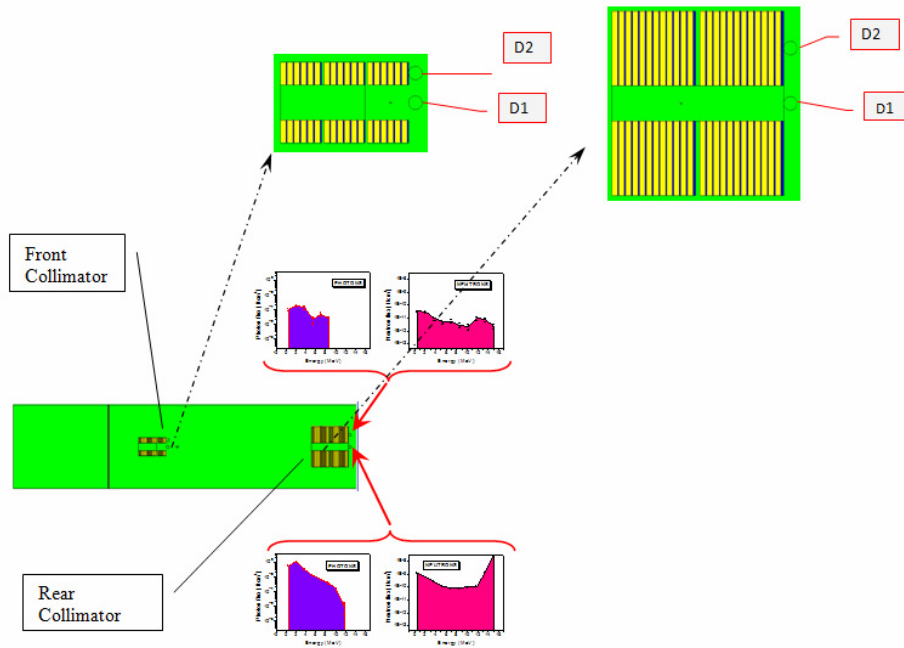

Figure 4.5 - Simulation results for CONFIG5 configuration – neutron and photon induced energy distributions.

Table 4.2 - shielding factor for the CONFIG-5 configuration

D1/D2	Front collimator	Rear collimator
n	18 ± 1	307 ± 20
(n, γ)	3 ± 1	45 ± 5
γ (9MeV)	54 ± 13	795 ± 155

It can be observed that this new configuration would produce shielding factors of about 300 for 14 MeV neutrons, 50 for neutron-capture photons induced within the collimation structure and about 800 for a parasitic gamma-ray line of 9 MeV.

In conclusion the MCNP analysis demonstrates that, for both CONFIG-4 and CONFIG5 geometry configurations, the KM6T tandem collimators produce very good values for the shielding factor, both for neutrons and for the parasitic gamma-ray sources.

5. Conclusions

The proposed tandem of collimators provides a clear and well defined field of view at the plasma end of the diagnostic line-of-sight. It will also restore and improve the radiation protection offered by the KJ5 radiation shield (X-ray camera) removed at the 2004 shut-down. The design solutions chosen for the collimator in terms of location,

materials, installation and operation were agreed upon at a number of technical meetings that took place at JET.

In terms of shielding factors it has been shown that the proposed configuration performs well, particularly in configuration CONFIG 5 with boronated polyethylene plates.

Acknowledgements

The reported work includes contributions from the following people outside the EURATOM- MEdC Association: *T. Edlington, V. Kiptily, P. Prior, S. Sanders, B. Syme* (Association EURATOM-UKAEA/JOC, Culham Science Centre, Abingdon, UK), *G. Gros* (Association EURATOM-CEA, Cadarache, France), *A. Murari* (Association EURATOM-ENEA, RFX, Padova, Italy), and *L. Rios* (Association EURATOM-CIEMAT, CIEMAT, Madrid, Spain).

References

- [1] V. Kiptily et al., Nuclear Fusion 42, 999 (2002)
- [2] O.N. Jarvis et al., Nuclear Fusion 36, 1513 (1996)
- [3] Kiptily VG *et al* 2004 *Phys. Rev. Lett.* **93** 115001
- [4] Zoita VL *et al* 2009 *Fusion Eng. and Design* **84** 2052-2057
- [5] Zoita VL *et al* “Upgrade of the JET Tangential Gamma-Ray Spectrometer. Conceptual Design”, Symposium Fusion Engineering, San Diego, June 01, 2009
- [6] Zoita VL *et al* “Conceptual Design Report, Tangential Gamma-Ray Spectrometer, (KM6T TGRS)”, JET, Culham, Nov. 2008
- [7] J.F. Briesmeister, Editor, “MCNP4C - Monte Carlo N-Particle Transport Code System Version 4C”, Los Alamos National Laboratory, Los Alamos, New Mexico.